

STARBEAM

INSTALLATION INSTRUCTIONS

WARNING: ALWAYS INSTALL FIXTURES ACCORDING TO NATIONAL ELECTRICAL CODE (NEC) AND LOCAL CODES. FAILURE TO DO SO WILL VOID THE WARRANTY AND COULD CAUSE DAMAGE TO THE FIXTURE OR MAY RESULT IN PERSONAL INJURY.

IMPORTANT: TURN ELECTRICITY OFF AT THE CIRCUIT BREAKER BEFORE INSTALLING OR PERFORMING MAINTENANCE ON FIXTURE.

This information deals with structures supplied by Eagle Mtn. along with certain safety issues. It is **NOT** a comprehensive description of how to install these structures. Installation contractors must be relied upon for equipment and practices that meet the conditions of each job location. Eagle Mtn. cannot be responsible for any damage that may occur during or after installation, or for any structure that has been modified by the purchaser or that is used in some way other than our application recommendations.

⚠ CAUTION: MAKE CERTAIN POWER SUPPLY IS DISCONNECTED DURING INSTALLATION!

HARDWARE KIT:

Junction Box Lid, (1) Junction Box Gasket, (1) Trim Ring Gasket, (6) 10-24 x 5/8" Torx Screws, (8) 10-24 x 1" Torx Screws, (2) 3/4" NPT Plug, (2) 1/2" NPT Plug, Mastic, Potting Compound, (3ea) Silicone Filled Wire Nuts

TOOLS REQUIRED FOR ASSEMBLY: (Provided by Others)

T25 Torx Driver
3/16 Hex Key or Hex Bit Driver

INSTALLATION IN SOIL

1. Excavate hole for fixture placement and conduit runs. Hole should be approximately 15.00" deep and 15.00" in diameter (FIGURE 1). Allow for a 3" minimum gravel base fill to assist drainage. Install conduit fittings using Teflon tape or other thread sealant and pull supply conductors into the junction box.
2. Position the STARBEAM rough-in housing and back fill hole with an appropriate substrate such as soil or gravel/sand mixture. Do not back fill with bark, vermiculite.
3. Make connections to the incoming supply conductors, BLK to Line, WHT to COM or NEUT, & GRN to GROUND using the silicone filled wire nuts provided and seal conduit entries from inside the junction box using the mastic provided per (FIGURE 2).
4. Remove all debris from the junction cavity and housing. Mix potting compound per instructions (3M Gelpak) and pour into junction cavity making sure connections are fully covered by the compound. Make sure gasket surfaces are clean!
5. Install junction box cover and gasket with the six (6) 10-24 x 5/8" Torx Screws provided. Torque screws 20-24 in/lbs.

NOTE: FAILURE TO PROPERLY WIRE AND ENCAPSULATE JUNCTION BOX WILL VOID PRODUCT WARRANTY.

6. Connect the female Driver Module connector to the male LED Module connector by aligning key and pushing connectors together then turn collar on male LED Module connector 1/4 turn to lock and seal. Be sure to turn collar until rotation stops. To adjust tilt aiming of the LED Module optics or reflector loosen the aim locking screw using a 3/16 Hex key wrench. Aim as desired and re-tighten the aim locking screw. Torque screw 30-35 in/lbs. to compress gasket. Install the LED Module finishing section onto the RIH (Rough-In-Housing) and rotate as desired for proper orientation towards object being illuminated. Using an alternating torque sequence, install all eight (8) 10-24 x 1" Torx screws until the LED module seats against the RIH, compressing the LED module sealing o-ring. Torque screws to 22-24 in/lbs. for proper seal. Lens frame should seat flush against the STARBEAM FIGURE 3 rim.
7. Supply power to circuit.

FIGURE 1 INSTALL ROUGH-IN HOUSING IN SOIL

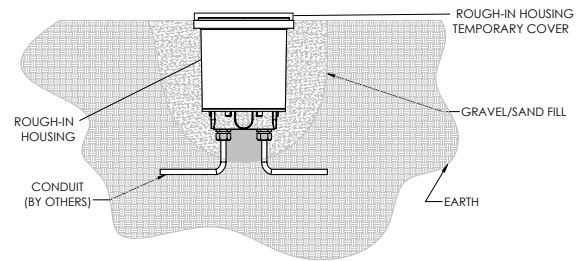

FIGURE 2 CONNECT POWER & INSTALL DRIVER MODULE

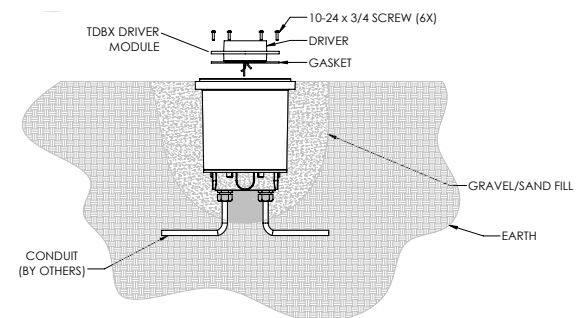
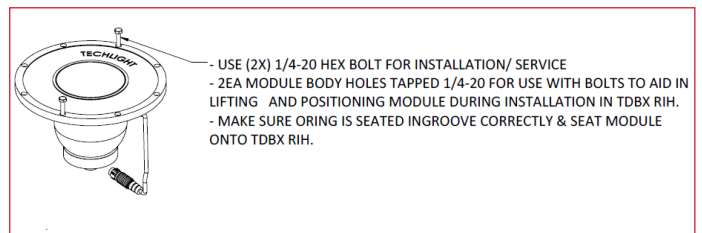
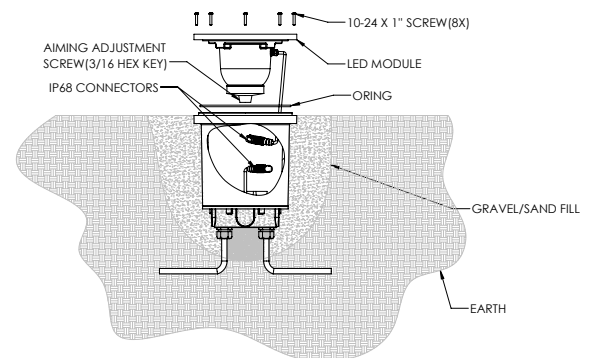

FIGURE 3 INSTALL LED MODULE INTO ROUGH-IN HOUSING



NOTES - Fixture must be installed by a licensed electrician. These instructions do not cover all details or variations in equipment, nor do they provide for every uncertainty related to installation, operation, maintenance, or mounting contingency. Should specific problems occur that are not covered sufficiently for the purchaser's purpose, contact Eagle Mtn. for additional product or application information. Improper installation and/or utilization may void manufacturer's warranty. Eagle Mtn. assumes no responsibility for claims arising out of improper or careless installation or handling of this product.

STARBEAM

INSTALLATION INSTRUCTIONS

WARNING: ALWAYS INSTALL FIXTURES ACCORDING TO NATIONAL ELECTRICAL CODE (NEC) AND LOCAL CODES. FAILURE TO DO SO WILL VOID THE WARRANTY AND COULD CAUSE DAMAGE TO THE FIXTURE OR MAY RESULT IN PERSONAL INJURY.

IMPORTANT: TURN ELECTRICITY OFF AT THE CIRCUIT BREAKER BEFORE INSTALLING OR PERFORMING MAINTENANCE ON FIXTURE.

This information deals with structures supplied by Eagle Mtn. along with certain safety issues. It is **NOT** a comprehensive description of how to install these structures. Installation contractors must be relied upon for equipment and practices that meet the conditions of each job location. Eagle Mtn. cannot be responsible for any damage that may occur during or after installation, or for any structure that has been modified by the purchaser or that is used in some way other than our application recommendations.

⚠ CAUTION: MAKE CERTAIN POWER SUPPLY IS DISCONNECTED DURING INSTALLATION!

INSTALLATION IN CONCRETE

NOTE: FAILURE TO PROPERLY WIRE AND ENCAPSULATE JUNCTION BOX WILL VOID PRODUCT WARRANTY.

1. Excavate hole for fixture placement and conduit runs. Hole should be approximately 15.00" deep and 15.00" in diameter (FIGURE 1). Allow for a 3" minimum gravel base fill to assist drainage. Install conduit fittings using Teflon tape or other thread sealant and pull supply conductors into the junction box.
2. Construct and place a rebar frame (by others) into the hole and level.
3. Place the concrete installation ring onto the rough-in housing and use the three (3) screw preparations to securely attach the ring to the housing. Position the STARBEAM housing per Figure 4. Housing rim must be flush to 1/8" above finish grade to allow water to run off.
4. Make connections to the incoming supply conductors, BLK to Line, WHT to COM or NEUT, & GRN to GROUND with the silicone filled wire nuts provided and seal conduit entries from inside the junction box using the mastic provided per Figure 3.
5. Tie the concrete installation ring to the rebar frame using holes in the pour frame ring.
6. Remove all debris from the junction cavity and housing. Mix potting compound per instructions (3M Gelpak) and pour into junction cavity making sure connections are fully covered by the compound. Make sure gasket surfaces are clean!
7. Install junction box cover and gasket with the six (6) 10-24 x 5/8" Torx Screws provided. Torque screws 20-24 in/lbs.
8. Replace the rough-in housing cover onto the rough-in housing prior to pouring concrete. Pour concrete. REMEMBER FIXTURE POSITION CANNOT BE ALTERED AFTER POURING CONCRETE.
9. Once concrete has set and is completely cured, remove RIH (Rough-In-Housing) cover. Install Finishing Section LED Module (FIGURE 2). Connect the female Driver Module connector to the male LED Module connector by aligning key and pushing connectors together then turn collar on male LED Module connector ¼ turn to lock and seal. Be sure to turn collar until rotation stops. To adjust tilt aiming of the LED Module optics or reflector loosen the aim locking screw using a 3/16 Hex key wrench. Aim as desired and re-tighten the aim locking screw. Torque screw 30-35 in/lbs. to compress gasket. Install the LED Module finishing section onto the RIH and rotate as desired for proper orientation towards object being illuminated. Using an alternating torque sequence, install all eight (8) 10-24 x 1" Torx screws until the LED module seats against the RIH, compressing the LED module sealing o-ring. Torque screws to 22-24 in/lbs. for proper seal. Lens frame should seat flush against the STARBEAM rim.
10. Supply power to circuit

FIGURE 1 ROUGH-IN HOUSING INSTALLED IN CONCRETE

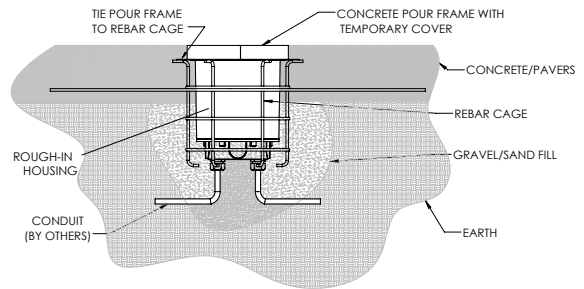
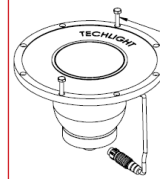
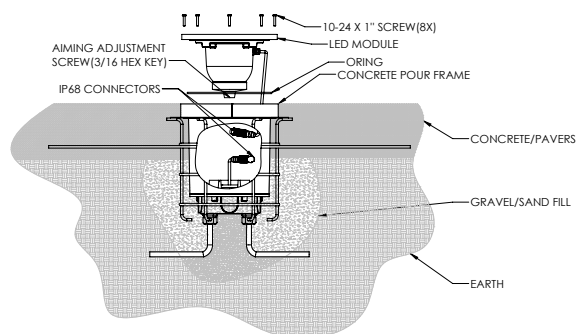

FIGURE 2 DRIVER & LED MODULES INSTALLED IN CONCRETE



- USE (2X) 1/4-20 HEX BOLT FOR INSTALLATION/ SERVICE
- 2EA MODULE BODY HOLES TAPPED 1/4-20 FOR USE WITH BOLTS TO AID IN LIFTING AND POSITIONING MODULE DURING INSTALLATION IN TDBX RIH.
- MAKE SURE ORING IS SEATED INTO GROOVE CORRECTLY & SEAT MODULE ONTO TDBX RIH.

NOTE: ALWAYS VERIFY THE VOLTAGE AT WHICH THE INCOMING POWER IS SUPPLIED. THE FIXTURE IS AUTO-RANGING FROM 120V TO 277V.

MAINTENANCE

Accumulated debris on top of the fixture will cause excessive heat build-up which may result in premature failure. It is the responsibility of the installing contractor to:

- Ensure the fixture is properly installed.
- Ensure the fixture is grounded in accordance with applicable local, state and national electrical codes.
- Instruct the owner in the required maintenance.
- Periodically clean lens with ammonia-based glass cleaner for optimum output.

NOTES - Fixture must be installed by a licensed electrician. These instructions do not cover all details or variations in equipment, nor do they provide for every uncertainty related to installation, operation, maintenance, or mounting contingency. Should specific problems occur that are not covered sufficiently for the purchaser's purpose, contact Eagle Mtn. for additional product or application information. Improper installation and/or utilization may void manufacturer's warranty. Eagle Mtn. assumes no responsibility for claims arising out of improper or careless installation or handling of this product.